

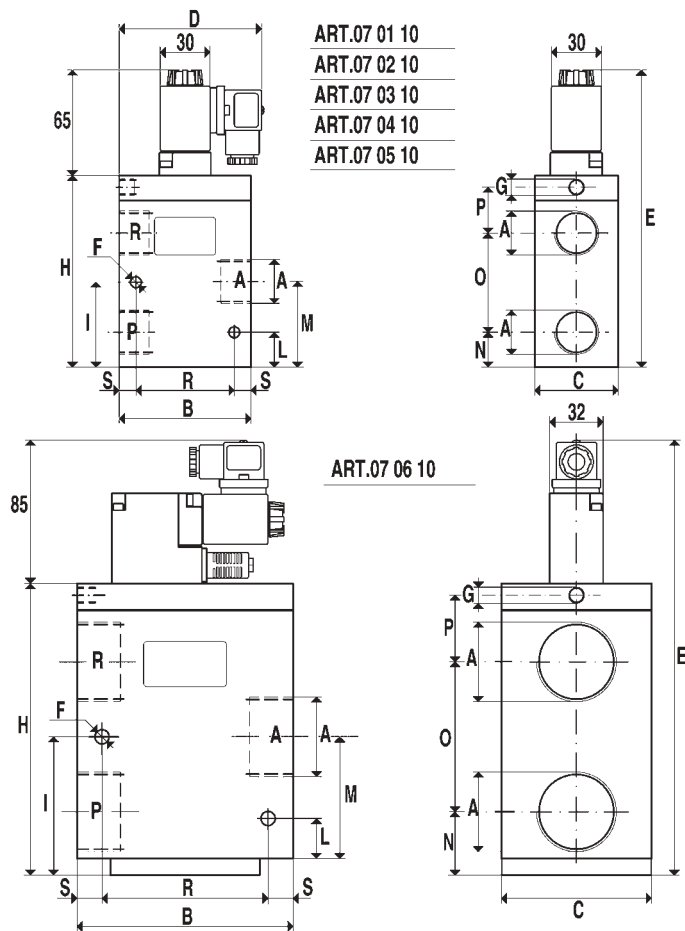

## [3-way vacuum solenoid valves]



ART.07 01 10  
ART.07 02 10  
ART.07 03 10  
ART.07 04 10  
ART.07 05 10

ART.07 06 10

The three-way vacuum solenoid valves of this series are with two positions, with pneumatically servo controlled conical valves, normally closed or open. The body is in anticorrosive aluminium, the valves and the membrane of the servo control are in Vulkollan.

As this valve has no frictions and internal dynamic stresses, the result is a high response speed and a guarantee of long lasting operation.

Working pressure: from 0 to 3 bar abs.

Pressure at the servo control: from 4 to 8 bar (g).

The electric coil is standard, completely plasticized in synthetic resin, tight execution, insulation class F (up to 155°C) electrical connections by means of a plug with clamping screws.

Acceptable tolerance on the nominal value of the voltage  $\pm 10\%$ .

Max. input: 17 V.A. with A.C. and 10 Watt with D.C. The coil may be rotated through 360°.

Three-way vacuum solenoid valves are normally used for vacuum interception on feeders and cup stackers, robots, sheet feeders, sack openers and in all those cases where a quick response is needed between the suction and the air inlet into the circuit.

| Art.     | A         | Ø    | B   | C  | D  | E   | F   | G    | H   | I  | L  | M    | N    | O  | P  | R   | S    |
|----------|-----------|------|-----|----|----|-----|-----|------|-----|----|----|------|------|----|----|-----|------|
|          | Ø orifice |      |     |    |    |     | Ø   | Ø    |     |    |    |      |      |    |    |     |      |
| 07 01 10 | 1/4"      | 8.5  | 50  | 35 | 72 | 140 | 5.5 | 1/8" | 75  | 30 | 10 | 32.5 | 12.5 | 35 | 21 | 40  | 5.0  |
| 07 02 10 | 3/8"      | 11.5 | 50  | 35 | 72 | 140 | 5.5 | 1/8" | 75  | 30 | 10 | 32.5 | 12.5 | 35 | 21 | 40  | 5.0  |
| 07 03 10 | 1/2"      | 15.0 | 60  | 40 | 77 | 155 | 6.5 | 1/8" | 90  | 35 | 15 | 38.5 | 15.5 | 45 | 22 | 45  | 4.5  |
| 07 04 10 | 3/4"      | 19.0 | 80  | 50 | 87 | 180 | 6.5 | 1/8" | 115 | 51 | 21 | 51.5 | 21.0 | 60 | 27 | 60  | 10.0 |
| 07 05 10 | 1"        | 25.0 | 80  | 50 | 87 | 180 | 6.5 | 1/8" | 115 | 51 | 21 | 51.5 | 21.0 | 60 | 27 | 60  | 10.5 |
| 07 06 10 | 1 1/2"    | 40.0 | 130 | 90 | -- | 260 | 8.5 | 1/8" | 175 | 85 | 34 | 85.0 | 38.0 | 90 | 40 | 100 | 15.0 |