

[Vacuum pumps VTS 25/FG, 30/FG, 35/FG]



They are dry vacuum pumps having a suction capacity of 25, 30, and 35 cum/h.

The particular shape of the working chamber and the special graphite which is used to manufacture the locking flanges and the vanes, allow these pumps to operate without any lubrication.

The rotor is splined on its shaft and it is supported by two bearings. The pump and electrical motor are two independent units coupled together by an elastic joint.

Cooling occurs by surface.

Heat is dispersed from the outer surface suitably finned, by means of a radial fan placed between motor and pump.

A filter is installed on the pump outlet and it operates as a silencer.

It is recommended to install proper a filter on the pump suction inlet to keep possible sucked impurities.

These pumps may not be used when the sucked fluid contains vapours or water or oil condensates.

This series of pumps can also be supplied with single-phase electric motors.

The table shows all data and technical features of this series of pumps.

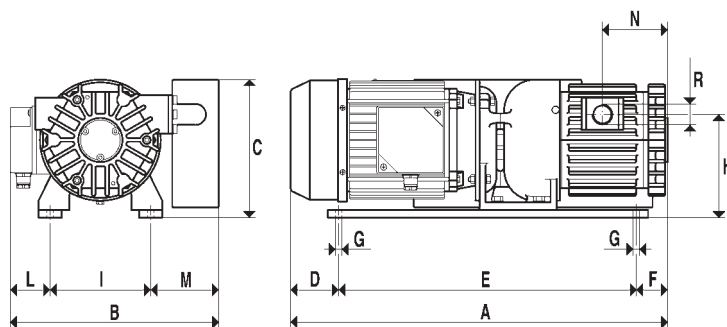

VTS		25/FG	30/FG	35/FG
Capacity	cum/h	25	30	35
Final pressure	mbar abs.	80	80	80
Motor execution	Volt	230/400 ± 10%, 50 Hz		
Motor power	Kw	0.88	1.0	1.0
Motor power	Hp	1.20	1.4	1.4
Rpm		1450	1450	1450
Max weight	Kg	28	32	34
A		470	490	510
B		265	265	265
C		170	170	170
D		65	65	65
E		385	385	385
F		20	40	60
G	∅	8.5	8.5	8.5
H		133	133	133
I		130	130	130
L		55	55	55
M		80	80	80
N		73	83	93
R	∅ gas	3/4"	3/4"	3/4"