

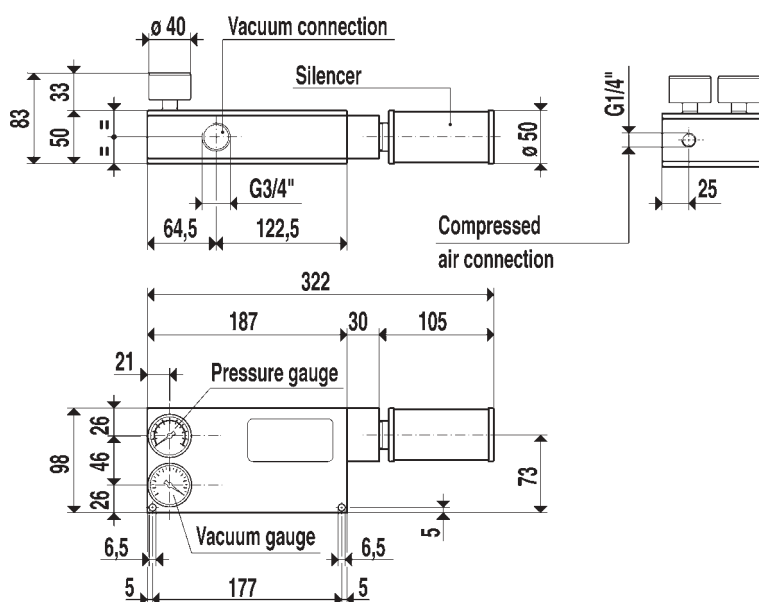

## [Vacuum generators PVP 25MD, 35MD and 50MD]



A line of ejectors of new design enabled us to develop this range of vacuum generators which have a very good ratio between the quantity of consumed air and the sucked one (volumetric efficiency) and for the possibility of the user to select the vacuum degree or the capacity depending on the pressure of the feeding air.

Fed by compressed air at an optimum pressure of 4 ÷ 6 bar, they are able to produce a maximum depression of 90%, equal to a final vacuum of 100 mbar, with suction capacities ranging from 33 to 56 cum/h, measured at the normal atmospheric pressure of 1013 mbar. Depending on the suction capacity, they consist of two, three or four sets of new ejectors based on the Venturi principle. The innovation of these generators consists in the exploitation of the kinetic energy of the feeding compressed air through several ejectors on line, properly sized, before releasing it into the atmosphere.

With the same suction capacity, this system allows a lower compressed air consumption compared to the traditional Venturi systems.

They are entirely manufactured in anodized aluminium, with lamellar valves and gaskets in special compounds, and they are all equipped, currently, with a silencer on the air outlet.

Art.		PVP 25MD	PVP 35MD	PVP 50MD
Supply pressure	bar (g)	4 5 6	4 5 6	4 5 6
Maximum vacuum level	-KPa	67 85 90	67 85 90	67 85 90
Final pressure	mbar (a)	330 150 100	330 150 100	330 150 100
Air consumption	NI/s	2.4 2.8 3.2	3.6 4.2 4.8	4.8 5.6 6.4
Vacuum air flow	cum/h	33 37 40	41 46 50	46 51 56
Working temperature	°C	-20/+80	-20/+80	-20/+80
Weight	Kg	1.710	1.730	1.750

N.B.: All the vacuum values shown in the table are valid at normal atmospheric pressure of 1013 mbar (a) and obtained with a constant supply pressure.