

# [Cups with ball valve, self-locking support and release button for glass]



As the glass machine builders require stirrup systems that are more precise and safer, we have developed this new range of cups.

Besides the grip security, assured by the particular shape of the cup, their feature is the utmost precision in the height, whose nominal size has a tolerance of only five hundredths of millimetre.

They are comprised of:

- A sturdy support in anodized aluminium with a wide surface at the base, delimited by a packing, which has the purpose to fasten it to the bearing surface.
- A special flat cup, vulcanized on its metal support, for the grip of the glass to be clamped.
- A ball valve having the feature to open, and therefore to produce vacuum inside the cup, only when the glass to be held actuates the sealing ball.
- Two rapid fittings for connection to the vacuum source.
- A release button which allows positioning of the support also when vacuum is connected.

The vacuum interception for the grip and detachment of the support from the bearing surface and for the grip and the release of the glass can be done by means of vacuum valves or three-way solenoid valves.

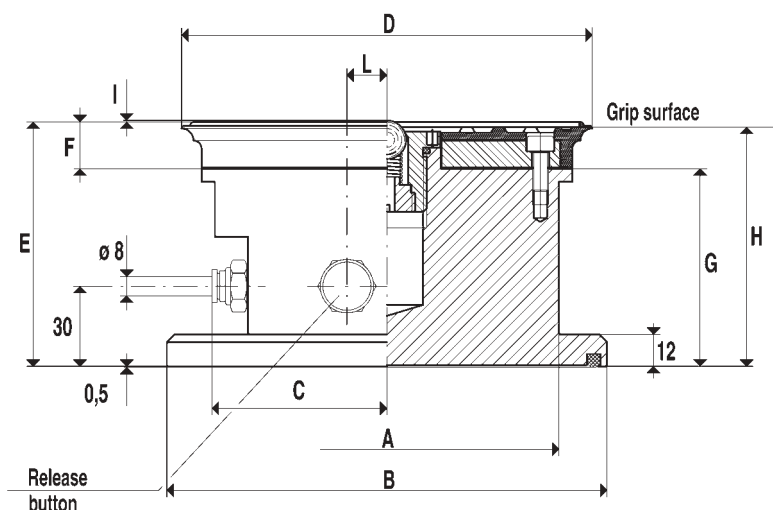

Art.	Force Kg.	A Ø	B Ø	C	D Ø	E	F	G	H	I	L	Art. Cup
21 85 11/90	12.0	70	98	42	85	92.5	17.5	75	90	1	--	08 85 11
21 150 11/90	42.7	129	165	73	150	92.5	17.5	75	90	1	15	08 150 11