

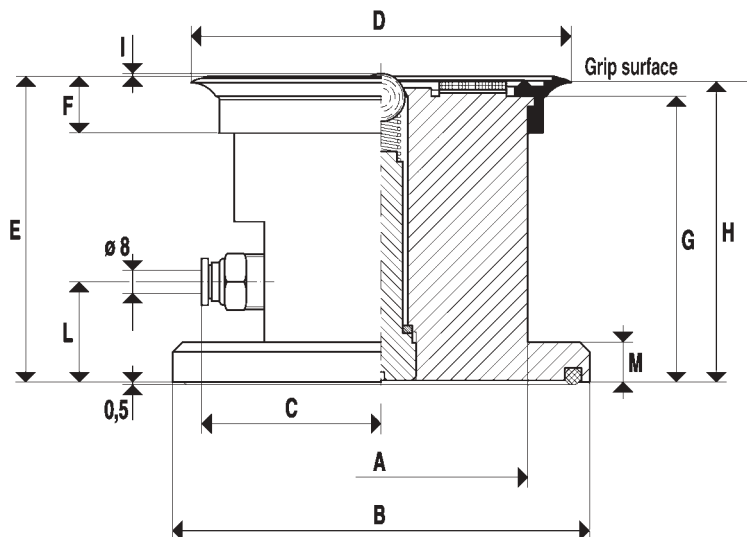

## [Cups with ball valve and self-locking support]



These cups represent a real movable stirrup system.

They consist of:

- A sturdy support in anodized aluminium with a wide surface at the base, delimited by a packing which has the purpose to fasten it to the bearing surface.
- A standard flat cup, cold assembled on the upper part of the support, for the grip of the load to be clamped.
- A ball valve having the feature to open, and therefore to produce vacuum inside the cup, only when the load to be kept actuates the sealing ball.
- Two rapid fittings for the connection to vacuum.

MT abbreviation indicates the cups with the gripping surface covered by a special plastic anti-skid surface, particularly suitable for securing glass and smooth marble.

The vacuum interception for the grip and detachment of the support from the bearing surface and for the grip and the release of the load, can be done by means of vacuum valves or three-way solenoid valves.

All the cups with self-locking support of this series and of the other series have the grip surface situated at the same height and therefore can be used together regardless of their shape or size.

N.B.

With item No. 28, instead of 18, they are available with a support suitable for mechanical fixing.

| Art.           | Force Kg. | A   | B   | C   | D   | E    | F  | G    | H  | I | L  | M  |
|----------------|-----------|-----|-----|-----|-----|------|----|------|----|---|----|----|
|                |           | Ø   | Ø   |     | Ø   |      |    |      |    |   |    |    |
| 18 85 15/90    | 14.18     | 60  | 98  | 42  | 85  | 91.5 | 17 | 85.0 | 90 | 1 | 30 | 12 |
| 18 85 15/90MT  | 14.18     | 60  | 98  | 42  | 85  | 91.5 | 17 | 85.0 | 90 | 1 | 30 | 12 |
| 18 110 10/90   | 23.74     | 88  | 125 | 51  | 114 | 91.5 | 17 | 85.5 | 90 | 1 | 30 | 12 |
| 18 110 10/90MT | 23.74     | 88  | 125 | 51  | 114 | 91.5 | 17 | 85.5 | 90 | 1 | 30 | 12 |
| 18 150 10/90MT | 45.00     | 120 | 165 | 68  | 154 | 91.5 | 23 | 85.0 | 90 | 1 | 30 | 12 |
| 18 250 20/90MT | 122.60    | 223 | 270 | 121 | 254 | 91.5 | 23 | 85.0 | 90 | 1 | 33 | 15 |