

[Octopus systems]



The OCTOPUS system has been designed in response to the operational flexibility required by palletising robotics and vacuum operated lifting systems in general.

Actually this system allows the handling of objects with any shape and feature, provided that they have a reasonable transpiration, without any need to change or position a vacuum cup and also when their surface only occupies 5% of the whole suction plate. Of course the maximum weight of the load to be lifted will be proportionate to the grip surface.

The OCTOPUS systems shown on this page are constructed with a vacuum generator fed by compressed air, combined with a box sealed by a suction plate, which is covered by a special foam rubber, both made of a light alloy.

Inside the suction plate, an easily inspected stainless steel micro-net filter is installed, to protect the vacuum generator.

On the outside of the vacuum box one or more threaded connections are present for connection to solenoid valves which can be used for quick release systems.

The design of this suction plate allows a perfect fit on any surface to be handled, smooth, rough or irregular.

For example, with the same system it is possible to take and handle both the carton and the wooden pallet it is taken from.

These OCTOPUS systems can be supplied, on request, with sizes, suction plates and vacuum generators, different from the standard models listed in this catalogue.

N.B.

Code SO -- --X, only identifies the base box of the OCTOPUS system with the relevant suction plate PX. The vacuum generator listed in the table is not an integral part of the OCTOPUS system, consequently it has to be ordered separately using its own code.

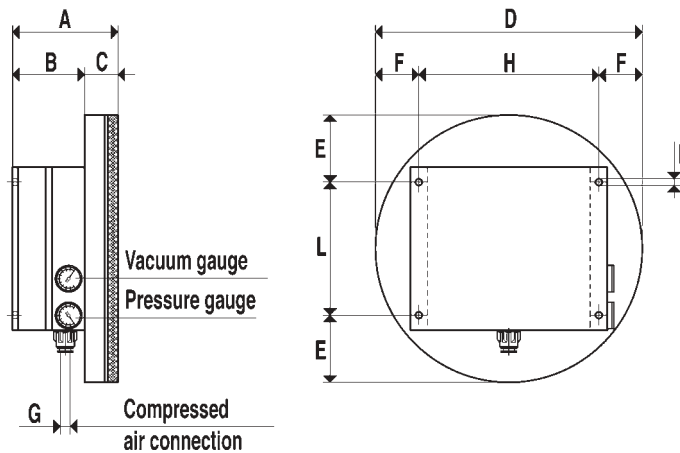

Art.		SO DO 35X	SO DO 50X
Suction plate	art.	PX DO 35	PX DO 50
Lifting force	Kg.	65.4	139.6
Vacuum generator	art.	PVP170M	PVP300MD
Supply pressure	bar (g)	4÷6	4÷6
Maximum vacuum level	-KPa	90	90
Max air consumption at 6 bar(g)	l/s	16	32
Vacuum air flow at 6 bar(g)	l/min.	2834	5834
Working temperature	°C	-20/+80	-20/+80
Weight	Kg.	9.5	17
A		146	158
B		96	108
C		50	50
D	∅	350	500
E		43	150
F		115	115
G	∅	15	15
H		120	270
I	∅	8.5	10.5
L		264	200

N.B.: All force values shown in the table are valid at normal atmospheric pressure of 1013 mbar (a) and obtained with a minimum vacuum level of -750 mbar.