

[Pneumatic blowing pumps PS40, PS70 and PS100]



A line of newly conceived ejectors allowed us to develop this range of pneumatic blowing pumps having an extraordinary ratio between the quantity of consumed and generated air, and to offer the user the possibility to adjust the pressure level and the capacity, based on the pressure of the supply air.

Fed by compressed air with a pressure ranging from 1 to 6 bar (g), they can produce a maximum pressure of 0,8 bar (g) and a blowing capacity ranging from 18 to 133 cum/h, measured at the normal atmospheric pressure of 1013 mbar.

When designing these new pumps, great consideration was given to noise levels and as they have no moving parts subject to wear and therefore no vibrations, they are extremely quiet in operation. Moreover, as they are based on the Venturi principle, they do not develop any heat.

As standard, they are provided with a filter-pressure regulator unit for the supply air and with a filter with micro porous cartridge placed on the air supply connection, in order to stop very thin and impalpable powders.

The excellent filtering of the compressed air supply and of the sucked air allows to blow in air free from oil vapours, water condensate and impurities between the sheets of paper to be separated and in the working environment, without any problem of pollution.

Using light alloys in the manufacture of these pumps, produces a light weight device enabling direct mounting on the machinery.

Thanks to their static operation principle, maintenance is limited to simple periodic filter cleaning only.

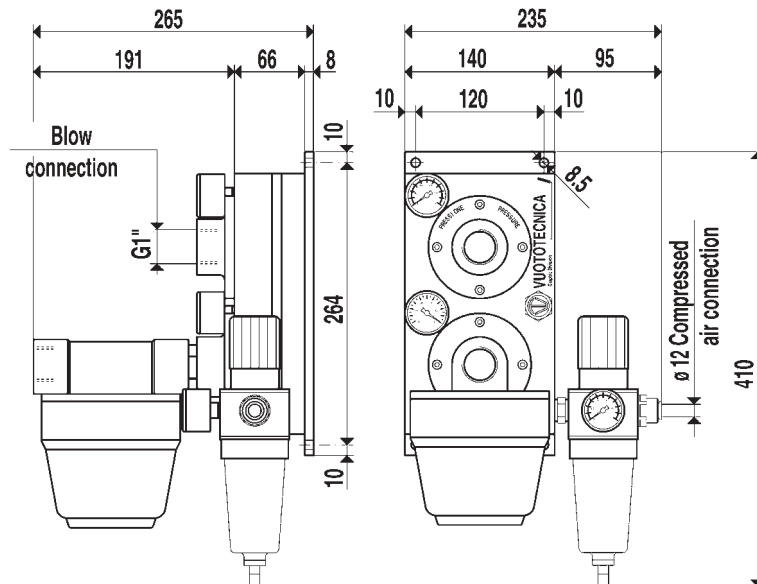

Art.	PS 40						
Supply pressure	bar (g)	1	2	3	4	5	6
Maximum blowing pressure	bar (g)	0.1	0.2	0.3	0.5	0.7	0.8
Air consumption	NI/s	1.0	1.5	2.0	2.4	2.8	3.2
Blow air capacity	cum/h	18	28	35	41	46	52
Weight	Kg	6.3					
Art.	PS 70						
Supply pressure	bar (g)	1	2	3	4	5	6
Maximum blowing pressure	bar (g)	0.1	0.2	0.3	0.5	0.7	0.8
Air consumption	NI/s	2.0	3.0	4.0	4.8	5.6	6.4
Blow air capacity	cum/h	33	51	65	74	83	92
Weight	Kg	6.3					
Art.	PS 100						
Supply pressure	bar (g)	1	2	3	4	5	6
Maximum blowing pressure	bar (g)	0.1	0.2	0.3	0.5	0.7	0.8
Air consumption	NI/s	3.0	4.5	6.0	7.2	8.4	9.6
Blow air capacity	cum/h	37	69	90	106	120	133
Weight	Kg	6.3					
Working temperature	°C	-20/+80					

N.B.: All the values shown in the table are valid at normal atmospheric pressure of 1013 mbar (a) and obtained with a constant supply pressure.