

[Supports with retractable reference pin]



The supports with reference pin described on this page have been manufactured in order to allow quick centering of the load to be stirred with cups to the operating surface of the machines.

The reference pin, integral with a piston, is operated by vacuum while retracting and remaining in its own seat and by a stainless steel spring while coming out.

These supports are mechanically fixed to the operating surface.

The reference pin is made in plastic material, while the support is in anodized anticorrosional aluminium.

As a standard they are equipped with a rapid fitting for connection to vacuum.

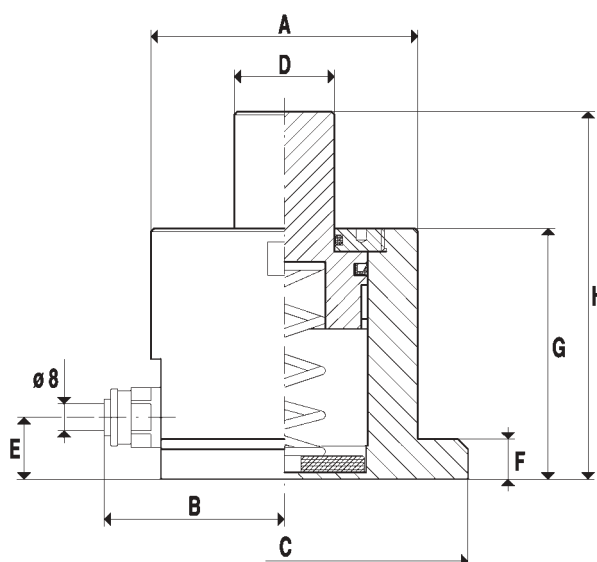

Art.	A \varnothing	B	C \varnothing	D \varnothing	E	F	G	H
23 01 10	80	53	110	30	18	12	45	63
23 01 15	80	53	110	30	13	12	64	99
23 02 10	80	53	110	30	18	12	75	110
23 05 10	80	53	110	30	18	12	110	180



[Cups with ball valve and self-locking support]

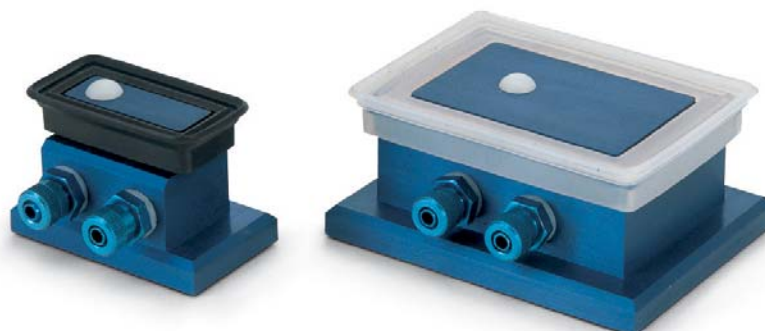

These cups represent a real movable stirrup system.

They consist of:

- A sturdy support in anodized aluminium with a wide surface at the base, delimited by a packing which has the purpose to fasten it to the bearing surface.
- A standard flat cup, cold assembled on the upper part of the support, for the grip of the load to be clamped.
- A ball valve having the feature to open, and therefore to produce vacuum inside the cup, only when the load to be kept actuates the sealing ball.
- Two semi-rapid fittings for the connection to vacuum.

The vacuum interception for the grip and detachment of the support from the bearing surface and for the grip and the release of the load, can be done by means of vacuum valves or three-way solenoid valves.

All the cups with self-locking support of this series and of the other series have the grip surface situated at the same height and therefore can be used together regardless of their shape or size.

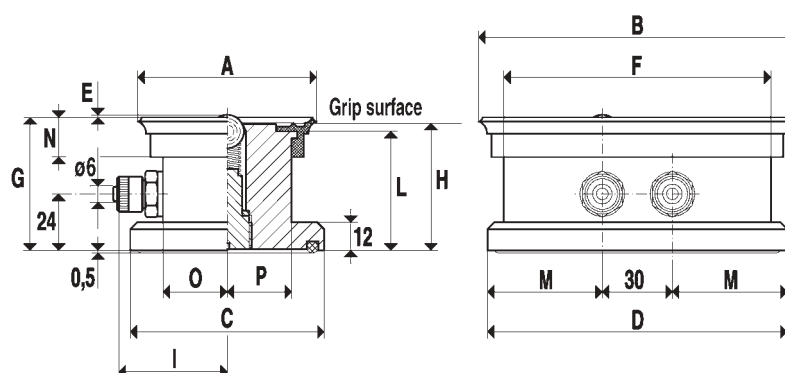

Art.	Force Kg.	A	B	C	D	E	F	G	H	I	L	M	N	O	P
18 40 75	6.7	41	76	48	83	2	55	56.5	54.5	41.5	51	26.5	16.0	21.0	15.0
18 120 90	24.0	90	120	98	128	1	102	57.0	54.5	56.0	50	49.0	17.5	35.0	35.0
18 150 75	25.0	75	150	83	144	1	130	57.0	54.5	48.0	50	57.0	16.5	27.5	27.5



[Cups with ball valve and self-locking support]

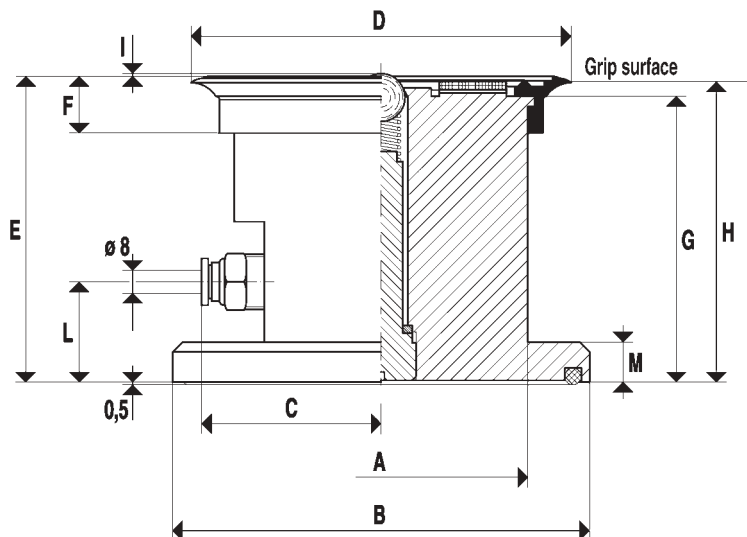

These cups represent a real movable stirrup system.

They consist of:

- A sturdy support in anodized aluminium with a wide surface at the base, delimited by a packing which has the purpose to fasten it to the bearing surface.
- A standard flat cup, cold assembled on the upper part of the support, for the grip of the load to be clamped.
- A ball valve having the feature to open, and therefore to produce vacuum inside the cup, only when the load to be kept actuates the sealing ball.
- Two rapid fittings for the connection to vacuum.

MT abbreviation indicates the cups with the gripping surface covered by a special plastic anti-skid surface, particularly suitable for securing glass and smooth marble.

The vacuum interception for the grip and detachment of the support from the bearing surface and for the grip and the release of the load, can be done by means of vacuum valves or three-way solenoid valves.

All the cups with self-locking support of this series and of the other series have the grip surface situated at the same height and therefore can be used together regardless of their shape or size.

N.B.

With item No. 28, instead of 18, they are available with a support suitable for mechanical fixing.

Art.	Force Kg.	A	B	C	D	E	F	G	H	I	L	M
		Ø	Ø		Ø							
18 85 15/90	14.18	60	98	42	85	91.5	17	85.0	90	1	30	12
18 85 15/90MT	14.18	60	98	42	85	91.5	17	85.0	90	1	30	12
18 110 10/90	23.74	88	125	51	114	91.5	17	85.5	90	1	30	12
18 110 10/90MT	23.74	88	125	51	114	91.5	17	85.5	90	1	30	12
18 150 10/90MT	45.00	120	165	68	154	91.5	23	85.0	90	1	30	12
18 250 20/90MT	122.60	223	270	121	254	91.5	23	85.0	90	1	33	15

[Cups with ball valve and self-locking support]

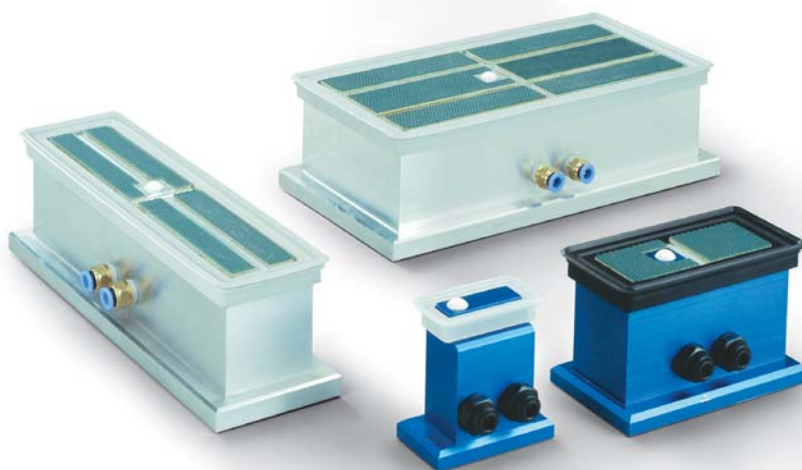

These cups represent a real movable stirrup system.

They consist of:

- A sturdy support in anodized aluminium with a wide surface at the base, delimited by a packing which has the purpose to fasten it to the bearing surface.
- A standard flat cup, cold assembled on the upper part of the support, for the grip of the load to be clamped.
- A ball valve having the feature to open, and therefore to produce vacuum inside the cup, only when the load to be kept actuates the sealing ball.
- Two rapid fittings for the connection to vacuum.

MT abbreviation indicates the cups with the gripping surface covered by a special plastic anti-skid surface, particularly suitable for securing glass and smooth marble.

The vacuum interception for the grip and detachment of the support from the bearing surface and for the grip and the release of the load, can be done by means of vacuum valves or three-way solenoid valves.

All the cups with self-locking support of this series and of the other series have the grip surface situated at the same height and therefore can be used together regardless of their shape or size.

N.B.

With item No. 28, instead of 18, they are available with a support suitable for mechanical fixing.

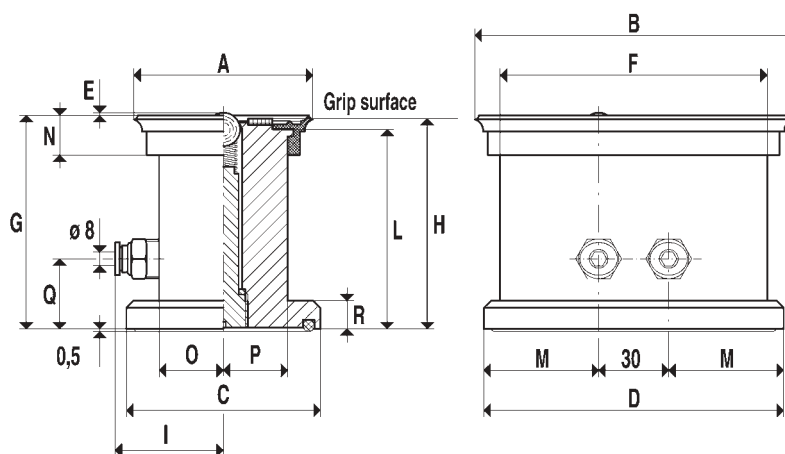

Art.	Force Kg.	A	B	C	D	E	F	G	H	I	L	M	N	O	P	Q	R
18 40 75/90	6.7	41	76	48	83	2	55	92.0	90	37.0	86.5	26.5	16.0	21.0	15.0	30	17
18 40 75/90MT	6.7	41	76	48	83	2	55	92.0	90	37.0	86.5	26.5	16.0	21.0	15.0	30	17
18 120 90/90	24.0	90	120	98	128	1	102	92.5	90	51.0	85.5	49.0	17.5	35.0	35.5	30	17
18 120 90/90MT	24.0	90	120	98	128	1	102	92.5	90	51.0	85.5	49.0	17.5	35.0	35.0	30	12
18 150 75/90MT	25.0	75	150	83	144	1	130	92.5	90	43.5	85.5	57.0	16.5	27.5	27.5	30	12
18 300 80/90MT	60.0	80	300	90	310	1	284	92.5	90	47.0	85.5	140	17.5	31.0	31.0	33	15
18 300 150/90MT	113.0	150	300	160	310	1	284	92.5	90	83.0	85.5	140	17.5	67.0	67.0	33	15



[Cups with ball valve and high self-locking support]

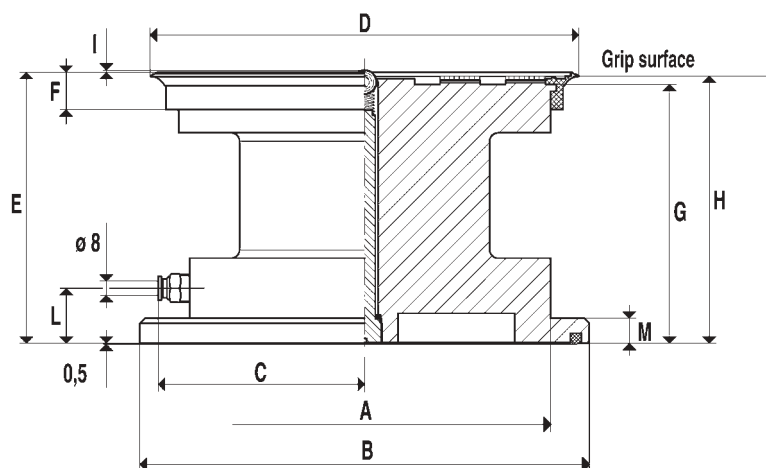

Art.	Force Kg.	A Ø	B Ø	C	D Ø	E	F	G	H	I	L	M
18 110 10/160MT	24.0	88	125	51	114	161.5	17	155.5	160	1	30	12
18 150 10/160MT	45.0	120	165	68	154	161.5	23	155.5	160	1	30	12
18 250 20/160MT	122.6	223	270	121	254	161.5	23	155.0	160	1	33	15

These cups represent a real movable stirrup system too, and they distinguish from the cups previously described for their exceptional height. They consist of:

- A sturdy support in anodized aluminium with a wide surface at the base, delimited by a packing which has the purpose to fasten it to the bearing surface.
- A special plastic anti-skid mat, particularly fit for securing of glass and smooth marble, covers the grip surface.
- A standard flat cup, cold assembled on the upper part of the support, for the grip of the load to be clamped.
- A ball valve having the feature to open, and therefore to produce vacuum inside the cup, only when the load to be kept actuates the sealing ball.
- Two rapid fittings for the connection to vacuum.

The vacuum interception for the grip and detachment of the support from the bearing surface and for the grip and the release of the load, can be done by means of vacuum valves or three-way solenoid valves.

All the cups with self-locking support of this series and of the other series have the grip surface situated at the same height and therefore can be used together regardless of their shape or size.

N.B.

With item No. 28, instead of 18, they are available with a support suitable for mechanical fixing.

[Cups with ball valve and high self-locking support]

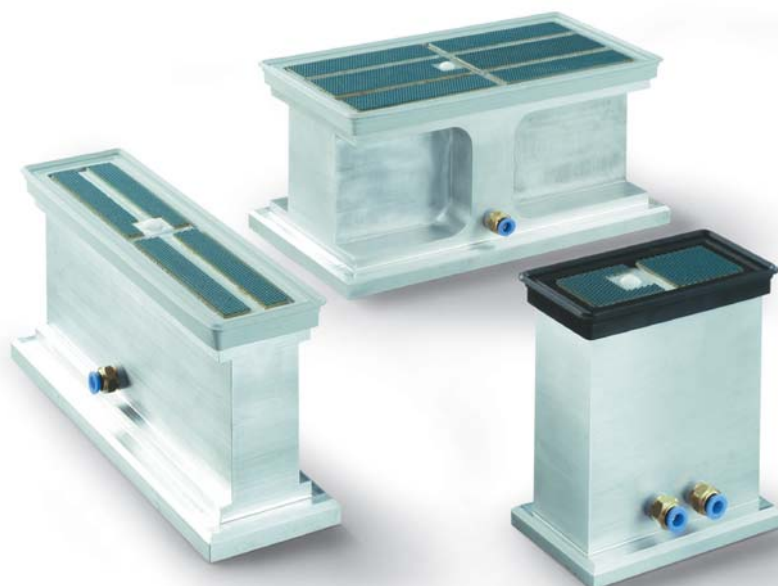

These cups represent a real movable stirrup system too, and they distinguish from the cups previously described for their exceptional height. They consist of:

- A sturdy support in anodized aluminium with a wide surface at the base, delimited by a packing which has the purpose to fasten it to the bearing surface.
- A special plastic anti-skid mat, particularly fit for securing of glass and smooth marble, covers the grip surface.
- A standard flat cup, cold assembled on the upper part of the support, for the grip of the load to be clamped.
- A ball valve having the feature to open, and therefore to produce vacuum inside the cup, only when the load to be kept actuates the sealing ball.
- Two rapid fittings for the connection to vacuum.

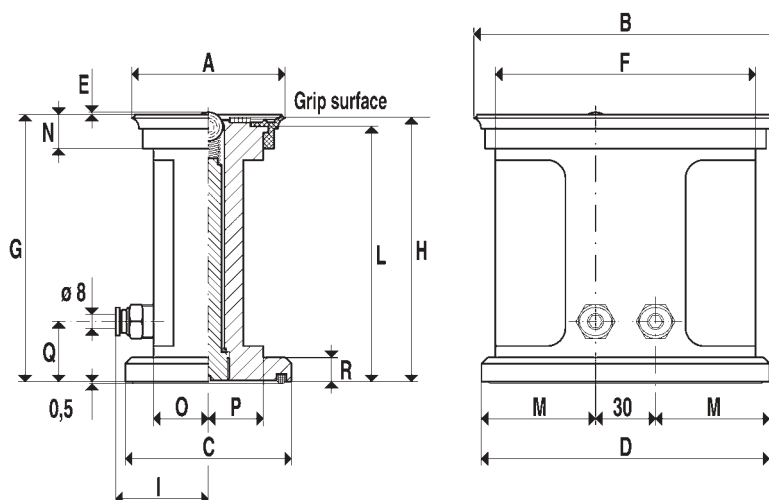

The vacuum interception for the grip and detachment of the support from the bearing surface and for the grip and the release of the load, can be done by means of vacuum valves or three-way solenoid valves.

All the cups with self-locking support of this series and of the other series have the grip surface situated at the same height and therefore can be used together regardless of their shape or size.

N.B.

With item No. 28, instead of 18, they are available with a support suitable for mechanical fixing.

Art.	Force Kg.	A	B	C	D	E	F	G	H	I	L	M	N	O	P	Q	R
18 120 90/160MT	24.0	90	120	98	128	1	102	162.5	160	51.0	85.5	49.0	17.5	35.0	35.0	30	12
18 150 75/160MT	25.0	75	150	83	144	1	130	162.5	160	43.5	85.5	57.0	16.5	27.5	27.5	30	12
18 300 80/160MT	60.0	80	300	90	310	1	284	162.5	160	47.0	85.5	140	17.5	31.0	31.0	33	15
18 300 150/160MT	113.0	150	300	160	310	1	284	162.5	160	83.0	85.5	140	17.5	67.0	67.0	33	15



[Cups with ball valve and self-locking support, for glass]

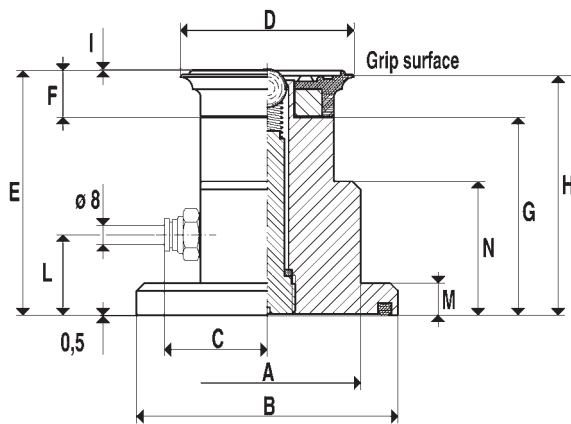

Art.	Force Kg.	A Ø	B Ø	C Ø	D Ø	E	F	G	H	I	L	M	N	Art. Cup
18 65 11/90	6.7	70	98	45	65	92.5	17.5	75	90	1	30	12	50	08 65 11

As the glass machine builders require stirrup systems that are more precise and safer, we have developed this new range of cups.

Besides the grip security, assured by the particular shape of the cup, their feature is the utmost precision in the height, whose nominal size has a tolerance of only five hundredths of millimetre.

They are comprised of:

- A sturdy support in anodized aluminium with a wide surface at the base, delimited by a packing, which has the purpose to fasten it to the bearing surface.
- A special flat cup, vulcanized on its metal support, for the grip of the glass to be clamped.
- A ball valve having the feature to open, and therefore to produce vacuum inside the cup, only when the glass to be held actuates the sealing ball.
- Two rapid fittings for connection to the vacuum source.

The vacuum interception for the grip and detachment of the support from the bearing surface and for the grip and the release of the glass can be done by means of vacuum valves or three-way solenoid valves.

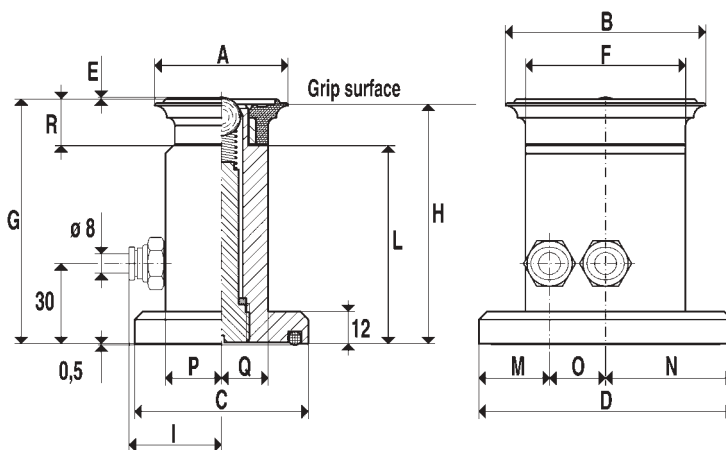

Art.	Force Kg.	A	B	C	D	E	F	G	H	I	L	M	N	O	P	Q	R	Art. Cup
18 50 75/90	7.5	50	75	65	95	1	60	92.5	90	41	75	26.5	47.5	21	21	17.5	17.5	08 50 75

[Cups with ball valve, self-locking support and release button for glass]



As the glass machine builders require stirrup systems that are more precise and safer, we have developed this new range of cups.

Besides the grip security, assured by the particular shape of the cup, their feature is the utmost precision in the height, whose nominal size has a tolerance of only five hundredths of millimetre.

They are comprised of:

- A sturdy support in anodized aluminium with a wide surface at the base, delimited by a packing, which has the purpose to fasten it to the bearing surface.
- A special flat cup, vulcanized on its metal support, for the grip of the glass to be clamped.
- A ball valve having the feature to open, and therefore to produce vacuum inside the cup, only when the glass to be held actuates the sealing ball.
- Two rapid fittings for connection to the vacuum source.
- A release button which allows positioning of the support also when vacuum is connected.

The vacuum interception for the grip and detachment of the support from the bearing surface and for the grip and the release of the glass can be done by means of vacuum valves or three-way solenoid valves.

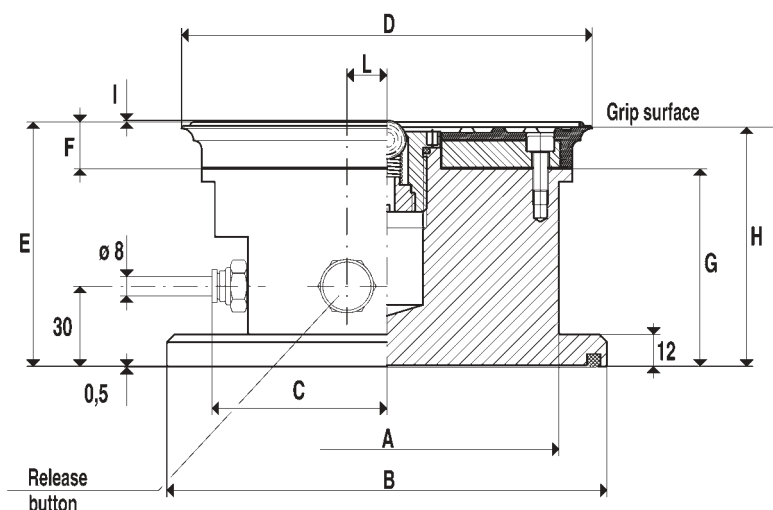

Art.	Force Kg.	A Ø	B Ø	C	D Ø	E	F	G	H	I	L	Art. Cup
21 85 11/90	12.0	70	98	42	85	92.5	17.5	75	90	1	--	08 85 11
21 150 11/90	42.7	129	165	73	150	92.5	17.5	75	90	1	15	08 150 11



[Cups with ball valve, self-locking support and release button]

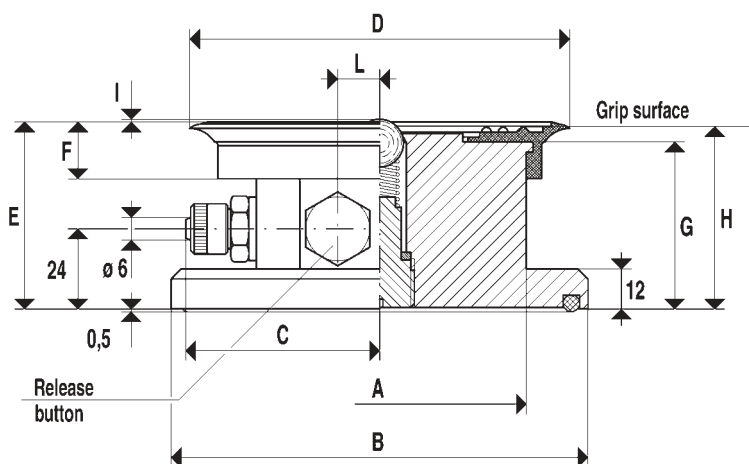

These cups represent a real movable stirrup system.

They consist of:

- A sturdy support in anodized aluminium with a wide surface at the base, delimited by a packing which has the purpose to fasten it to the bearing surface.
- A standard flat cup, cold assembled on the upper part of the support, for the grip of the load to be clamped.
- A ball valve having the feature to open, and therefore to produce vacuum inside the cup, only when the load to be kept actuates the sealing ball.
- Two semi-rapid fittings for the connection to vacuum.
- A release button which allows positioning of the support also when vacuum is connected.

The vacuum interception for the grip and detachment of the support from the bearing surface and for the grip and the release of the load, can be done by means of vacuum valves or three-way solenoid valves.

All the cups with self-locking support of this series and of the other series have the grip surface situated at the same height and therefore can be used together regardless of their shape or size.

Art.	Force Kg.	A Ø	B Ø	C	D Ø	E	F	G	H	I	L
21 110 10	24	88	125	58	114	56.0	17	50.0	54.5	1	10
21 150 10	45	120	165	76	154	57.5	23	49.5	54.5	1	28